

Electric Press Work Station

Press Range 1kN to 1,000kN

The Promess Work Station has been designed for a range of uses including part testing, part development, prototype builds, process development, and training.

The Work Station is a stand-alone unit with a Promess servo press and motion controller. The system has the ability to press to a programmable position, to a programmable force, to a rate of change or any other process variable that can be measured with an external sensor. These are just a few of the features of the press system.

Unlike the traditional hydraulic press systems, the Promess Work Station is completely electric. Because the press incorporates the latest servo technology, there are no hydraulic components to maintain (cylinder, pump, valves, or oil).



WORK STATION INCLUDES

- Promess Ball Screw Servo Press
- Promess motion controller
- Force transducer
- Press stand with C-frame
- Light curtain
- Guarding
- Programming software

MONITORING CAPABILITIES

- Force vs. position signature monitoring
- Data acquisition
- Display of force vs. position graphs, zooming and printing
- Gauging functions
- Adjustable process limits and tolerances

FEATURES AND BENEFITS

- Flexibility
- Programmable stop points (positions)
- Programmable speed and acceleration
- Press to position
- Press to force
- Press to rate of change
- Data acquisition
- Push and pull capabilities

OPTIONS

- External position transducers
- Additional load cell ranges
- Door
- Panel PC with enclosure and keyboard tray



ELECTRIC PRESS WORK STATION SIZES

Force (kn)	Stroke (mm)	Speed (mm/sec)
0.2	100	200
1	100, 300	200, 150
3	100, 300	200
5	200, 350	200
8	200, 350, 500	200
12	200, 350, 500	200
20	350, 550	200
30	350, 550	200
40	330, 660	200

Force (kn)	Stroke (mm)	Speed (mm/sec)
60	330, 660	200
80	330, 660	200
100	330, 660	200
120	330, 660	175
160	400	100
200	400	100
300	400	100
500	400	70
1000	400	50

ELECTRIC PRESS WORK STATION DIMENSIONS

Size 1 Work Station

The Size 1 Work Station is designed to support 1kN, 5 kN, 8 kN and 12 kN Promess EMAP presses.

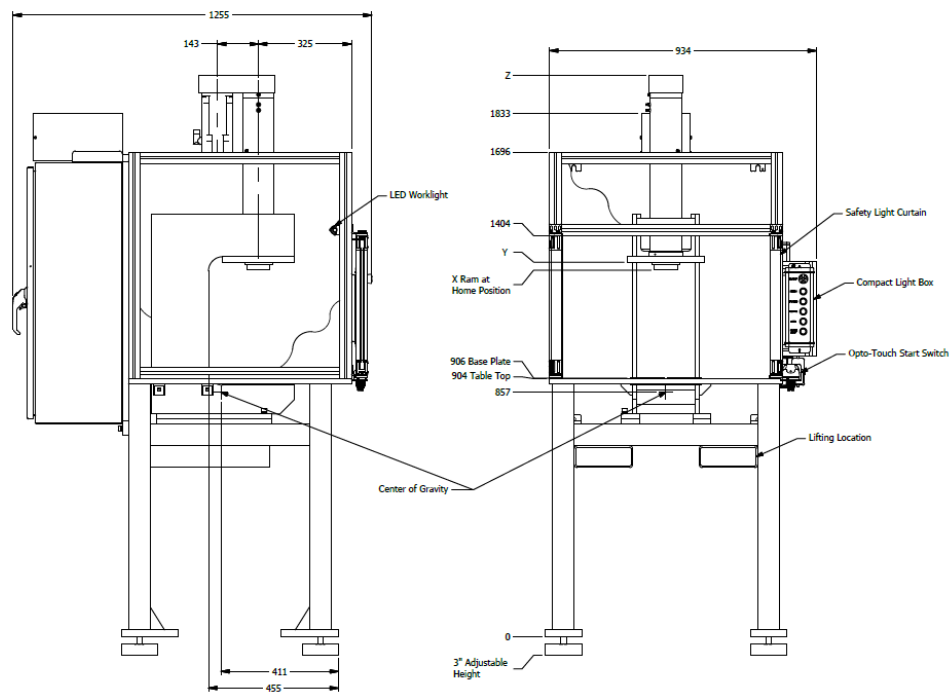

ELECTRIC PRESS WORK STATION DIMENSIONS

Size 2 Work Station

The Size 2 Work Station is designed to support 8kN, 12kN, 20 kN and 30 kN Promess EMAP presses.

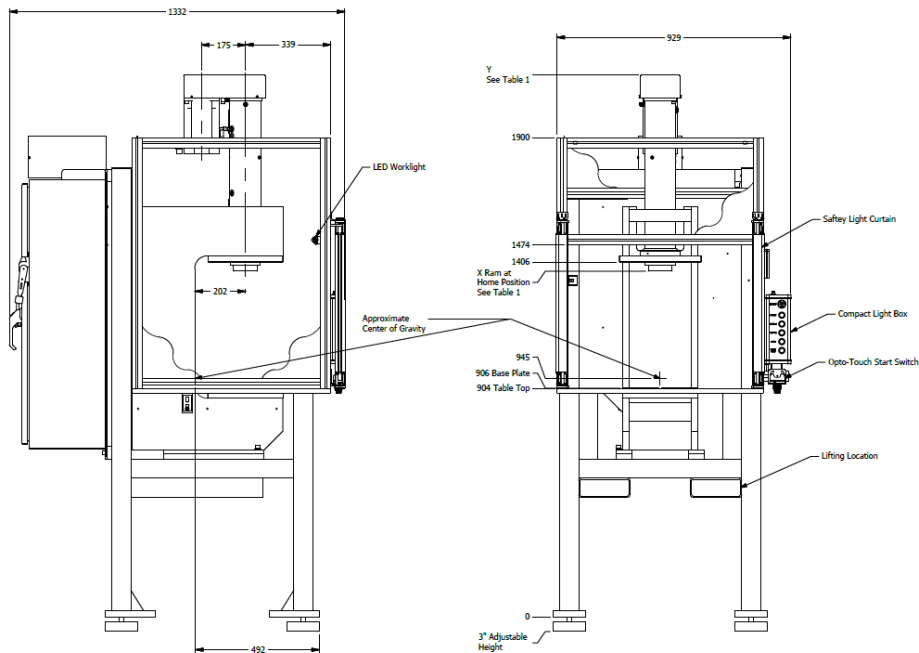

Size 3 Work Station

The Size 3 Work Station is designed to support 40 kN, 60 kN, 80 kN, 100 kN and 120 kN Promess EMAP presses.

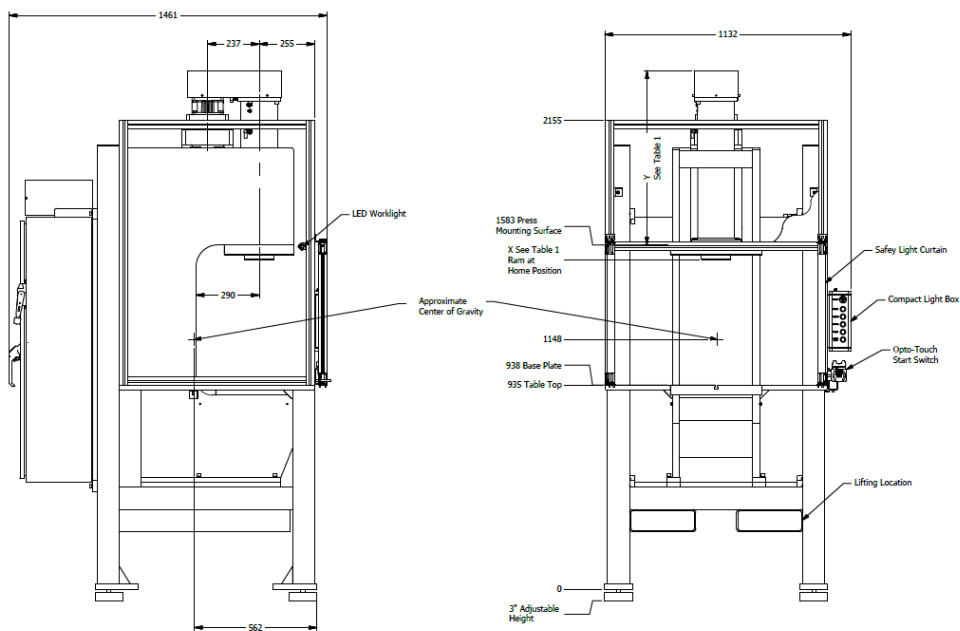

ELECTRIC PRESS WORK STATION DIMENSIONS

Size 4 Work Station

The Size 4 Work Station is designed to support 160 kN, 200 kN and 300 kN Promess EMAP presses.

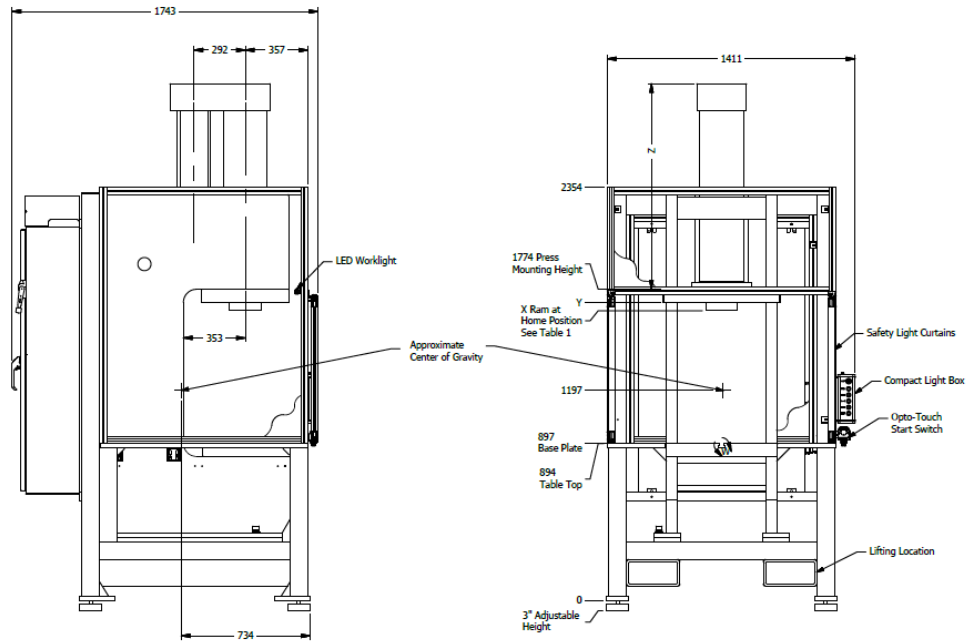

Size 5 Work Station

The Size 5 Work Station is designed to support 500 kN Promess EMAP presses.

