

# SLIMLINE PRESS

The Promess Slimline Press delivers the same functional performance and process capability as the Promess EMAP press, but in a significantly smaller, space-optimized housing.

This slim architecture allows the presses to be installed in tighter locations or arranged with extremely small center-to-center distances.

Engineered for applications where every millimeter matters, the Slimline Press maintains full servo precision, force capability, and process control while enabling more flexible machine layouts and higher-density assembly designs.

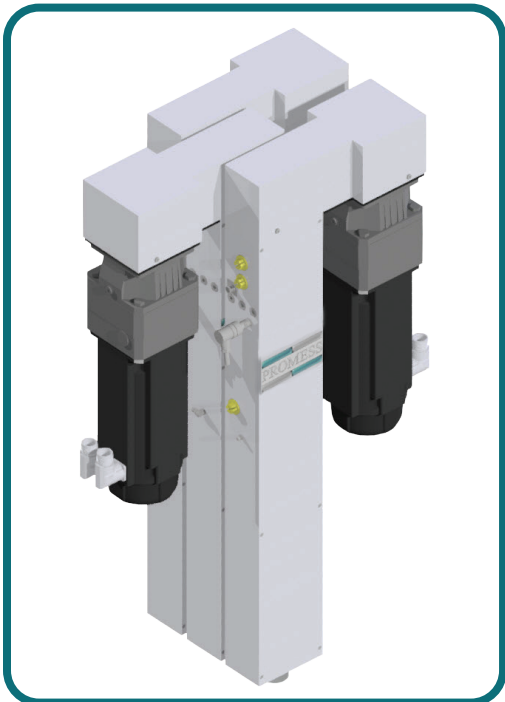
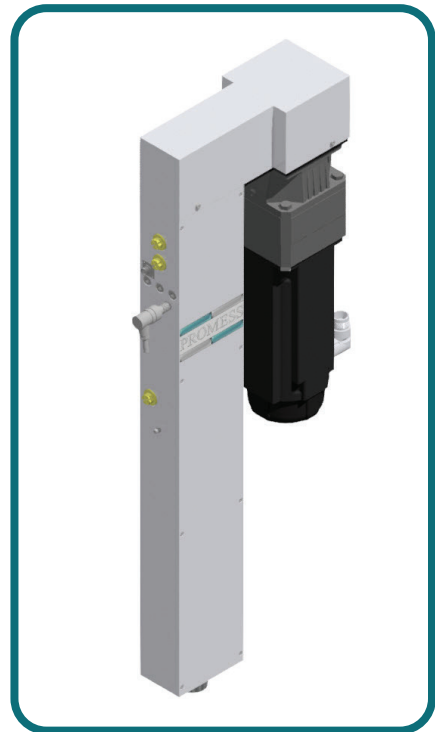

## INCLUDED WITH SYSTEM

- + Fully electric
- + Fully programmable
- + Data acquisition and storage
- + In-process verification and monitoring
- + Integrated load cell

## SIZES

- + 25/350/200
- + 50/350/200

